

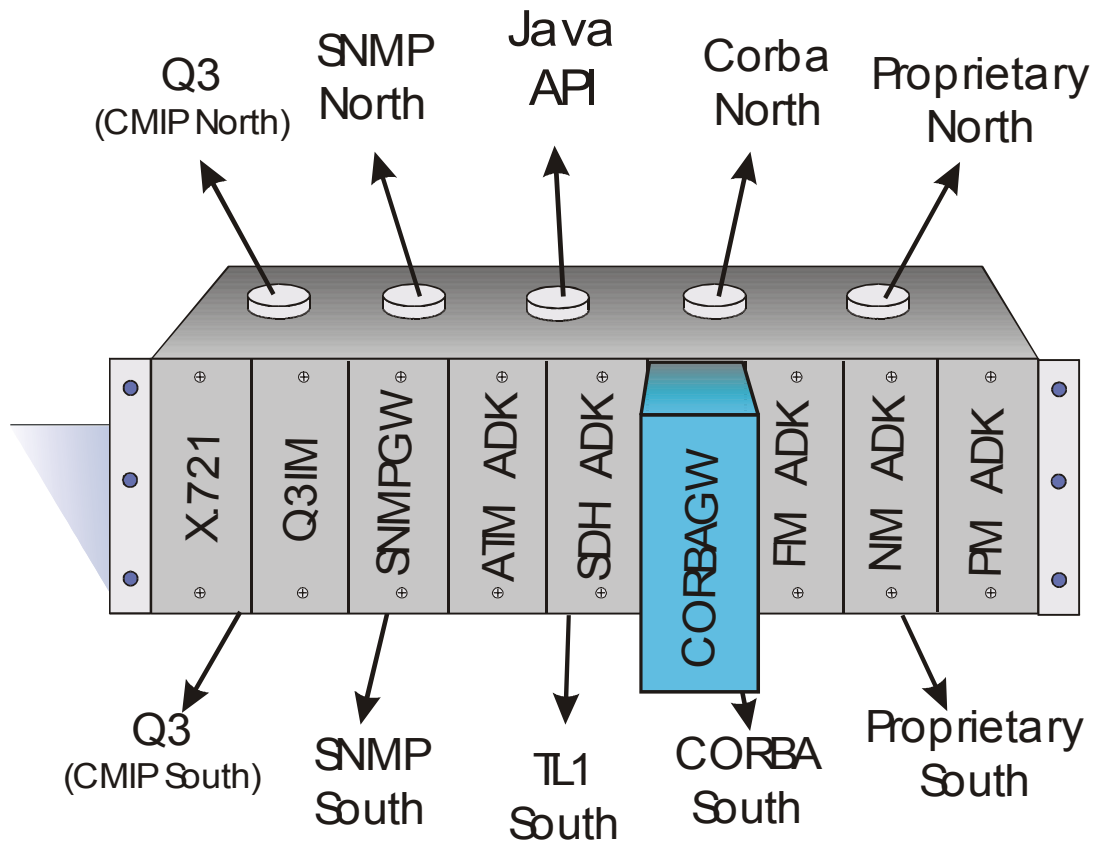

# The Q3ADE<sup>®</sup> CORBA Gateway





Copyright © 2000-2001 UH Communications A/S.

UH Communications A/S  
Telegrafvej 5  
DK-2750 Ballerup, Denmark  
ph. +45 4468 0864, fax +45 4468 0805

Information in this document is subject to change without notice. Companies, names and data used in examples herein are fiction unless otherwise noted.

No warranty is given with respect to the correctness or timeliness of the information in this document.

No part of this document may be reproduced or transmitted in any form or by any means, electronic or mechanical, for any purpose, without the express written permission of UH Communications A/S.

Comments or questions may be submitted via electronic mail to [product@uhcommunications.com](mailto:product@uhcommunications.com).

Visual C++, Windows NT, Windows 2000 and Windows 95 are registered trademarks of Microsoft Corporation.

UNIX is a trademark of Unix System Laboratories, Inc.

Solaris is a registered trademark of Sun Microsystems Inc.



## CONTENTS

---

<b>INTRODUCTION</b>	<b>5</b>
The Q3ADE® CORBA Gateway	5
Benefits	6
<b>FEATURE SUMMARY</b>	<b>7</b>
Functions	8
Interfaces	8
<b>DESIGN GOALS</b>	<b>9</b>
Scalability	9
Runtime Configuration	9
Interoperability	9
Standardized Translation Principles	10
Adding the Power of Q3ADE®	10
IDL or GDMO/ASN.1 - You Choose	10
<b>APPLICATION SCENARIOS</b>	<b>11</b>
Stand-alone Gateway (Northbound)	12
Heterogeneous Agents (Northbound)	13
Stand-alone Gateway (Southbound)	13
Decoupling Model Translation from Protocol Translation	14
<b>SPECIFICATIONS</b>	<b>16</b>
Host requirements	16
Standards conformance	16

---

## FIGURES

---

<b>Figure 1: Outline of the Q3ADE® CORBA Gateway</b>	<b>7</b>
<b>Figure 2: A sample gateway configuration</b>	<b>11</b>
<b>Figure 3: A stand-alone Northbound CORBA Gateway</b>	<b>12</b>
<b>Figure 5: A heterogeneous agent</b>	<b>13</b>
<b>Figure 6 A stand-alone Southbound CORBA Gateway</b>	<b>14</b>
<b>Figure 7: Southbound Model-Protocol Translation Decoupling</b>	<b>15</b>
<b>Figure 8: Northbound Model-Protocol Translation Decoupling</b>	<b>15</b>

uh

# INTRODUCTION

Today's Service providers, e.g. Telecom, Finance, Transport will have to extend their Network Management systems to cross administrative domains and to span multiple technologies in order to fulfil the increasing demands for service availability. This will require a framework that supports interoperability between a wide range of management technologies.

The future of IT and infrastructure management will not be dominated by a single technology, but rather be a challenge of mastering numerous communications technologies to form an integrated information base for mission critical business applications, like Customer care, billing, trouble management etc.

In the world of telecommunications management, the currently dominating technologies are CORBA, SNMP and CMIP. But technologies like XML, SOAP, LDAP and TL1 play important roles in different context.

But CORBA is currently the leading technology when it comes to developing portable distributed management applications.

This implies a need for integration between CORBA and all the other management technologies. The Q3ADE CORBA Gateway enables this integration as a component in Q3ADE®.

## The Q3ADE® CORBA Gateway

The purpose of Q3ADE is to integrate and present real-time system information from many heterogeneous sources into a homogeneous view abstracting the underlying technologies.

Q3ADE represents an integrated line of software tools and applications that enable flexible and seamless access to management information in a wide range of telecom equipment and applications.

The Q3ADE CORBA Gateway is a component in the Q3ADE product that enables accesses from CORBA client applications to all the management technologies integrated into Q3ADE, like CMIP (Q3) agents and SNMP agents.

The Q3ADE CORBA Gateway also provides access to CORBA Servers from CMIP based Management applications.



The Q3ADE CORBA Gateway is provided for Windows NT<sup>®</sup>, Windows 2000<sup>®</sup> and Sun Solaris<sup>®</sup>.

## Benefits

As a CORBA management application provider you will appreciate the technology transparency provided by the CORBA Gateway, e.g. shielding protocol details, object naming and location, security etc. All issues that makes the task of developing integrated management applications seriously complex and hart to maintain.

Through the multiple languages supported you may choose between C, C++, Java, Smalltalk and even COBOL and FORTRAN.

You will also appreciate the immense scalability in the amount of data that can be managed and the number of events captured, which ranges far beyond what the "raw" CORBA technology offers. The powerful scoping and filtering functionality of CMIP/Q3 (much like SQL and LDAP) enables you to offload the raw data selection tasks to the CORBA Gateway. And when this capability is combined with the ability to distribute the CORBA Gateway functionality over several platforms, you have the best possible insurance that your application will scale with the demand.

The CORBA Gateway will also offload tasks like availability monitoring, QOS monitoring, statistics collection, event routing from the CORBA management application.

As a TMN management application provider you will appreciate the ability to access CORBA Servers as a fully integrated Q3 agents. You may even apply scooping and filtering to extract the objects you need.

As an equipment provider you will appreciate the fact that you need only develop one agent application in your equipment and then provide both CMIP/Q3 and CORBA northbound interfaces to your customers.

# FEATURE SUMMARY

The Q3ADE<sup>®</sup> CORBA Gateway enables a tight integration between the CORBA based Business and Service Management world on one side and the CMIP based and SNMP based Telecommunications Management world on the other side.

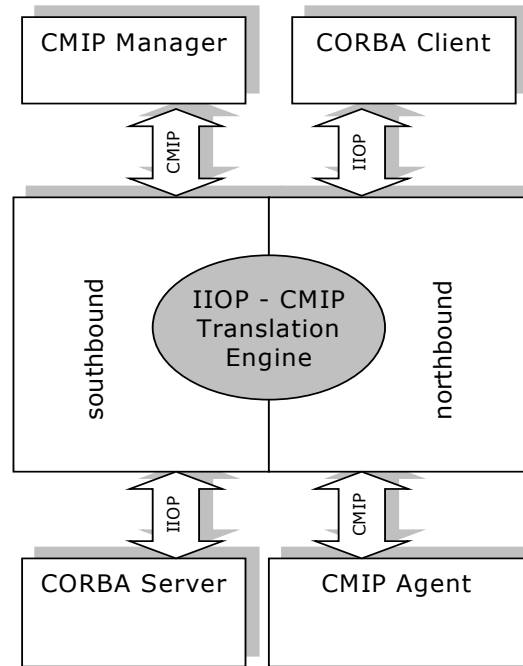

**Figure 1: Outline of the Q3ADE<sup>®</sup> CORBA Gateway**

This is done by providing the following functions and interfaces.



## Functions

- Data driven on-the-fly data protocol translation between Corba, CMIP and SNMP
- Automatic bi-directional model translation between the model specifications from the CORBA world (in IDL), the TMN world (in GDMO) and the Internet world (SNMP/SMI1)
- Automatic availability monitoring
- Persistent data logging of events
- Advanced event filtering and forwarding functions including selection on contents, multicasting and backup destinations
- Advanced remote data value monitoring and statistics collection
- Integrated CORBA northbound and CORBA southbound gateway functionality allowing for numerous specialized application scenarios

## Interfaces

The Q3ADE<sup>®</sup> CORBA Gateway provides the following interfaces:

- Operation access from Corba clients to CMIP Agents
- CMIP Events from CMIP Agents to CORBA Events
- CORBA Events to CMIP Events
- Operation access from TMN (CMIP) Managers to Corba Servers

And if it is combined with the Q3ADE<sup>®</sup> SNMP Gateway it also provides:

- Operation access from Corba Clients to SNMP Agents
- SNMP Traps to Corba Events

# DESIGN GOALS

The primary requirements pursued in the design of the UHC CORBA gateway product have been to provide:

## Scalability

The gateway uses a stateless translation scheme. Therefore, the performance of the gateway is independent of the number and size of CMIP agents or CORBA servers. Furthermore it allows for the access to a configurable number of OSI agents.

## Runtime Configuration

The ability to reconfigure the gateway kernel while it is running is important in a number of situations.

One example is non-stop operation, where the gateway should remain operational at all times, due to alarm reporting, for instance.

Another example is simultaneous development of agent and management software where changes to the structure of management information must be incorporated in the gateway within a short interval of time.

The gateway satisfies these requirements by allowing for dynamic update of dictionary information to include new object classes, OSI agents or CORBA Servers at run-time. This is realized by implementing the dictionary information as a local MIB accessible through the Q3 protocol, the CORBA interface or the local management interface of the Gateway/Agent.

## Interoperability

The gateway is based on UH Communication's TMN development toolbox Q3ADE<sup>®</sup> which has been tested for interoperability with all the major TMN platform products.



## Standardized Translation Principles

The UHC CORBA Gateway product adheres to the interworking principles defined by the Open Group/NMF Joint Inter-Domain Management task force (JIDM).

The gateway solution includes JIDM compliant GDMO to IDL and IDL to GDMO compilers, providing the mapping information needed by the UHC CORBA gateway kernel.

Refer to [JIDM] for more information on the standardized scheme for specification and interworking translation.

## Adding the Power of Q3ADE<sup>®</sup>

Besides the basic CORBA-CMIP translation capabilities the gateway includes a long list of ready-to-use functions, having Q3ADE as its basis. These include

- X.734 compliant CMIS Event reception and redirection. See [X.734]
- X.735 compliant CMIS Event logging. See [X.735]
- Persistent Object storage
- Q3ADE's internal management and protocol profiling management MIB called Q3IM.
- Optional Quality of Service Performance monitoring through the Q3ADE X.738/X.739 ADK. See [X.738] and [X.739].
- Integrated SNMP Agent accessibility through the Q3ADE CMIP-to-SNMP ADK.

## IDL or GDMO/ASN.1 - You Choose

The need for using a gateway nearly always originate in the presence of some interface or protocol different from what you are able to handle. So normally you do not have the option to choose whether to start off with an IDL or GDMO/ASN.1 information model.

However, the Q3ADE<sup>®</sup> CORBA Gateway with its two compilers, IDL to GDMO/ASN.1 and GDMO/ASN.1 to IDL allows you to handle both situations.

# APPLICATION SCENARIOS

In the following we will discuss the range of applications that the gateway can play a role in.

A full-fledged example of what Q3ADE<sup>®</sup> can do relating to the CORBA Gateway is shown in the figure below.

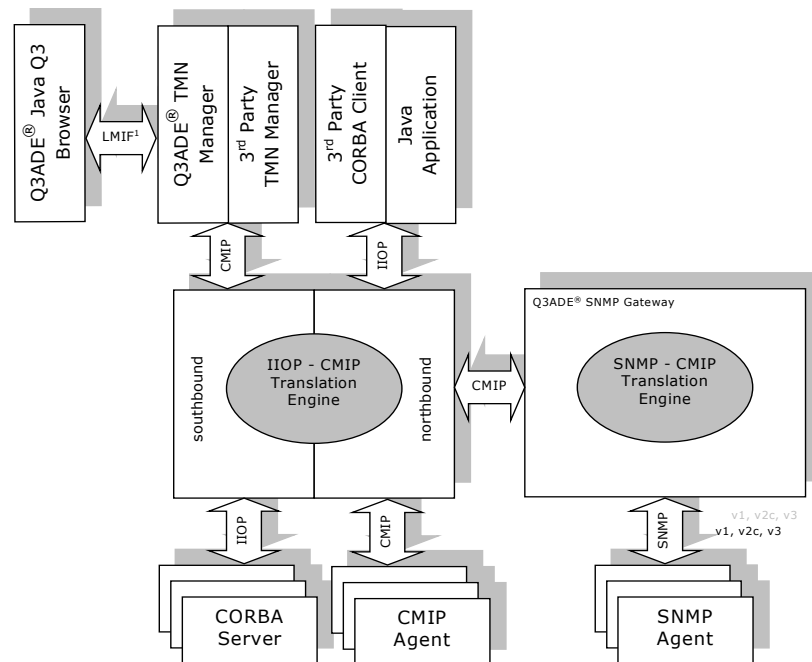

1) LMIF is a clear text encoding of CMIP. UHC proprietary.

**Figure 2: A sample gateway configuration**

In the following we will decompose this system into a number of (simpler) configurations and discuss those.

In general the northbound part of the gateway allows for CORBA based management of CMIP based Q3 agents, whereas



the southbound part of the gateway allows for CMIP based management of CORBA based servers.

One configuration is to use the product as a standalone gateway bridging between the CORBA and CMIS/CMIP technology domains as described in the following section.

## Stand-alone Gateway (Northbound)

As a stand-alone gateway the UHC gateway product provides a bridge between the CMIP/CMIS and CORBA technology domains in a heterogeneous management environment, enabling CORBA based management applications to view and control the contents of CMIP/CMIS or SNMP based agents.

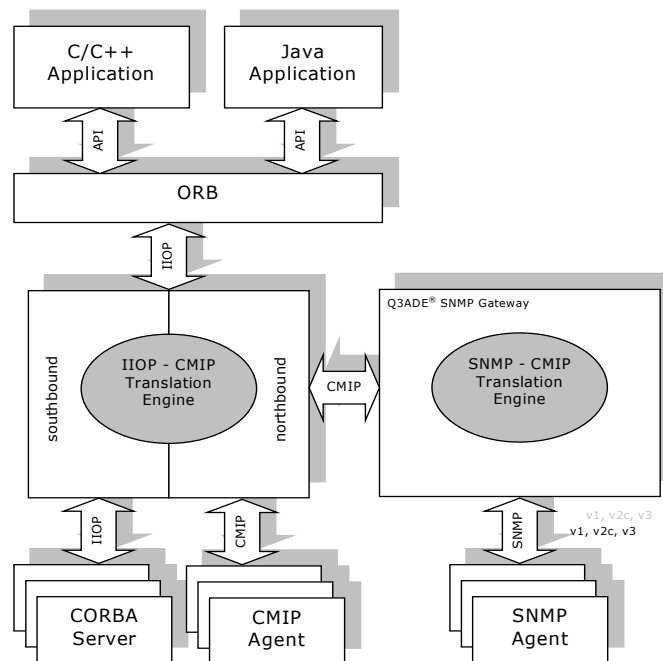

**Figure 3: A stand-alone Northbound CORBA Gateway**

The product can also be used to provide a standardized management API, which maps to a multiple number of implementation languages and through which CORBA, CMIP and SNMP based agents can be managed. This is described in the following section.

## Heterogeneous Agents (Northbound)

Heterogeneous agents are another field of usage for the gateway.

As the gateway product is based on the UHC TMN agent development toolkit Q3ADE ([Q3ADE]) it can furthermore be used to build heterogeneous agents. By using the generic agent development features of Q3ADE the gateway product allows for the implementation of agents that offer both CMIP/CMIS and CORBA managed interfaces.

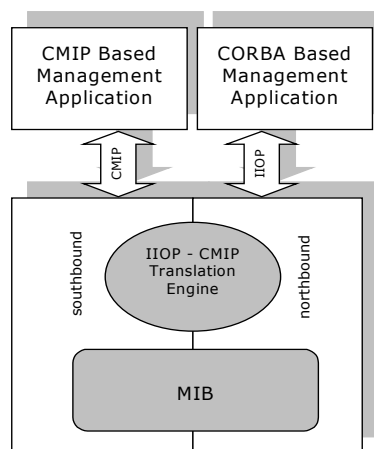
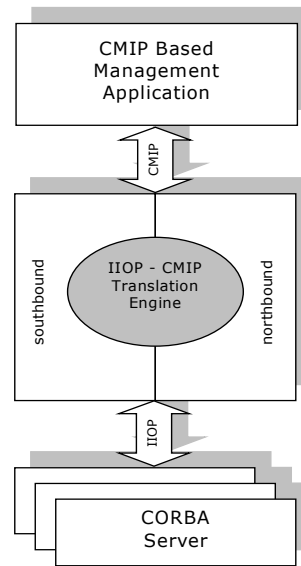

Figure 5: A heterogeneous agent

## Stand-alone Gateway (Southbound)

In general the southbound part of the gateway allows for CMIP based management of CORBA based servers.

As a stand-alone gateway the Q3ADE CORBA Gateway provides a bridge between the CMIP/CMIS and CORBA technology domains in a heterogeneous management environment, enabling CMIP/CMIS based managers to view and control the contents of CORBA objects residing in CORBA servers.



**Figure 6 A stand-alone Southbound CORBA Gateway**

## **Decoupling Model Translation from Protocol Translation**

CORBA based management interfaces are very often very API-like with a limited number of interfaces as well as a limited number of objects implementing these interfaces.

This is opposed to the TMN domain where tens or even hundreds of classes organized in a comprehensive inheritance hierarchy and thousands of instances tend to be more the rule than the exception.

These differences often call for nontrivial model translations when mediating between these two domains. On top of this is the problem of protocol translation.

However, using the Q3ADE<sup>®</sup> CORBA Gateway model translation can be decoupled from protocol translation by using one of the following configurations. Which one to use will depend on a lot of external parameters including the environment that the model translator has to run in, whether the developers know-how lies in the CORBA or CMIP domain etc.

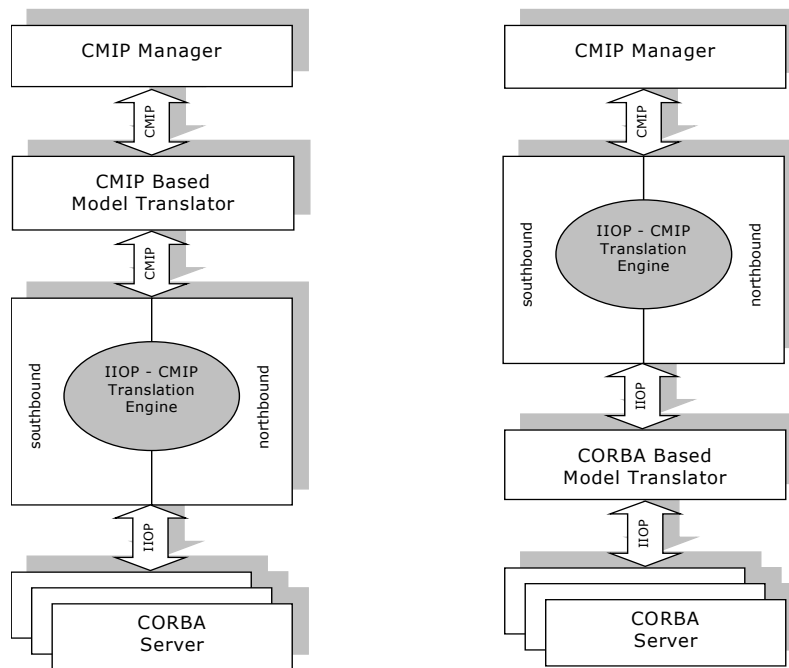

**Figure 7: Southbound Model-Protocol Translation Decoupling**

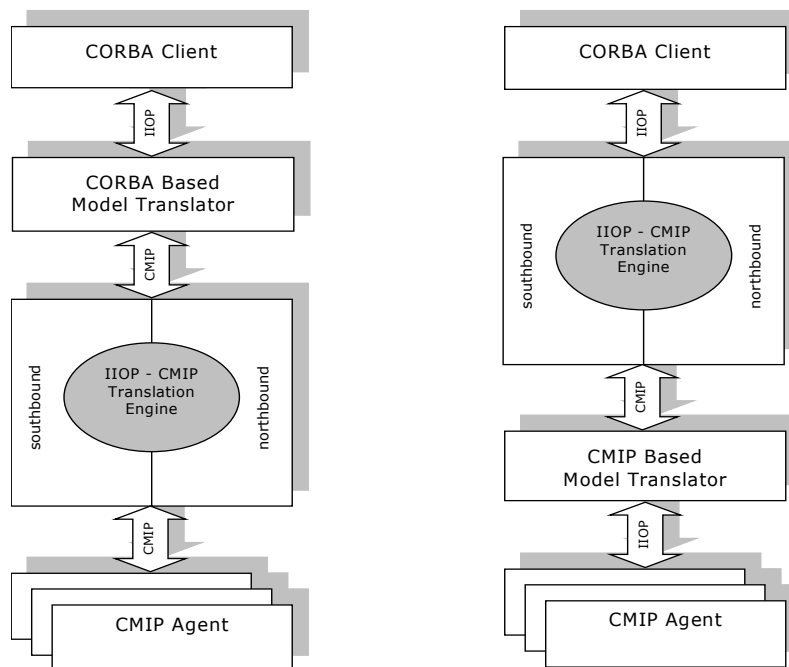

**Figure 8: Northbound Model-Protocol Translation Decoupling**



# SPECIFICATIONS

## Host requirements

On Windows NT<sup>®</sup>, Windows 2000<sup>®</sup>:

- CPU: Intel Pentium, IBM Compatible
- RAM: minimum 32MB for Runtime, 64MB for Development
- HD: minimum 20MB for Runtime, 200MB for Development
- Eicon<sup>®</sup> X.25 for X.25 communication (optional)
- On Windows 2000: Streamsoft TP4 (optional)
- Q3ADE SNMP Gateway (optional)

On Solaris 2.6:

- CPU: Sun Sparc compatible
- RAM: minimum 32MB for Runtime, 64MB for Development
- HD: minimum 20MB for Runtime, 200MB for Development
- Sunlink X.25 for X.25 communication (optional)
- Sunlink OSI for TP4/CLNP (optional)
- Q3ADE SNMP Gateway (optional)

Beyond this there are no requirements for 3<sup>rd</sup> party tools. But a 3<sup>rd</sup> party CORBA Tool is required for the development of the CORBA Client/Server applications.

## Standards conformance

The UHC CORBA/CMIP gateway is based on the UHC GIOP stack/ORB. The stack complies to the necessary parts of the OMG CORBA V2.1 specs:

- GIOP version 1.0
- IIOP version 1.0

The gateway interoperates with all OMG compliant ORBs.

Currently the gateway has been interoperability tested with the following ORBs.

- Orbix 3.0.1, Win32 (using Microsoft Visual C++) NT 4.0
- Orbix 3.0.1, Solaris 5.6 (using SPARCompiler C++ 4.2)
- OrbixWeb 3.0. (tested on NT, but should work on all Jdk1.1 enabled platforms)
- JavaIdl 3.0, Jdk 1.3 (tested on NT, but should work on all platforms with jdk 1.3)

The CMIP (Q3) Management interface (i.e. the southbound Q3 used to access CMIP/Q3 agents) complies fully to ITU X.711.

The following Q3 stack profiles are supported:

- CMIP over TP0 over X.25
- CMIP over TP4 over CLNP
- CMIP over TP0 over TCP/IP (also called RFC1006)

The support of these protocol profiles may require 3<sup>rd</sup> party software and/or hardware as specified under the platform requirements.

The CMIP/Q3 Agent interface (I.e. the northbound Q3 interface used to provide Q3 Agent service to Q3 Manager's) complies fully to ITU X.711.

The CMIP/Q3 interfaces have been interoperability tested with all leading TMN protocol stacks, e.g. HP OpenView<sup>®</sup>, TeMIP<sup>®</sup>, Bull Openmaster<sup>®</sup>, Solstice<sup>®</sup>, Vertel<sup>®</sup>, DSET<sup>®</sup>, TMN 6000<sup>®</sup> and a number of proprietary stacks, e.g. Siemens, Alcatel, NTT, Osimis.

The southbound CORBA Gateway functionality (i.e. providing Q3 Agent access to CORBA Servers) provides object naming, scoping and filtering functionality according to X.710 and X.720 to the extent it is possible to map automatically to equivalent CORBA Services. It should be noted that many CORBA Servers are very "low-level" when it comes to object filtering functionality, and hence appear equivalently low level on the Q3 northbound interface.

The Event management functionality provided by the CORBA Gateway complies fully to ITU X.734 and X.735.

The performance monitoring functionality provided by the CORBA Gateway complies fully to ITU X.738 and X.739.